



CORDA®

- DE FallGerüst
- GB Folding scaffold
- PL Rusztowanie składane
- HU Összecsukható állvány
- RU Складные подмости
- BG Сгъваемо скеле с платформа
- CZ Skladací lešení

- DK Foldestillads
- EE Klappellingud
- ES Andamio plegable
- FI Taitteline
- FR Echafaudage repliable
- GR Αναδιπλούμενη σκαλωσιά
- HR/BA Zglobna pokretna skela

- IS Hjólappallur hraðpallur
- IT Trabattello pieghevole
- LV Salokāmās sastatnes
- NL Vouwsteiger
- NO Foldestillas
- PT Andaimes rebativeis

- RO Schelă pliantă
- RS/ME Zglobna pokretna skela
- SE Vikningsställning
- SI Zložljiv oder
- SK Skladateľné pojazdné lešenie
- TR Katlanır platform

NEW

1

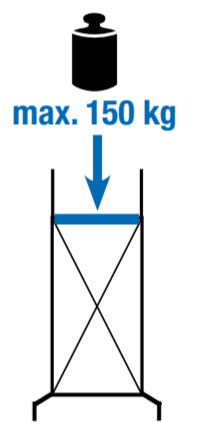

561150 • © 2022 KRAUSE-Werk • Am Kreuzweg 3 • D-36304 Alsfeld

Art.-No.	1			(ca. m)	
	A	B	C	A	ca. kg
916211	2,90	0,90	1,75	1,75	15,2

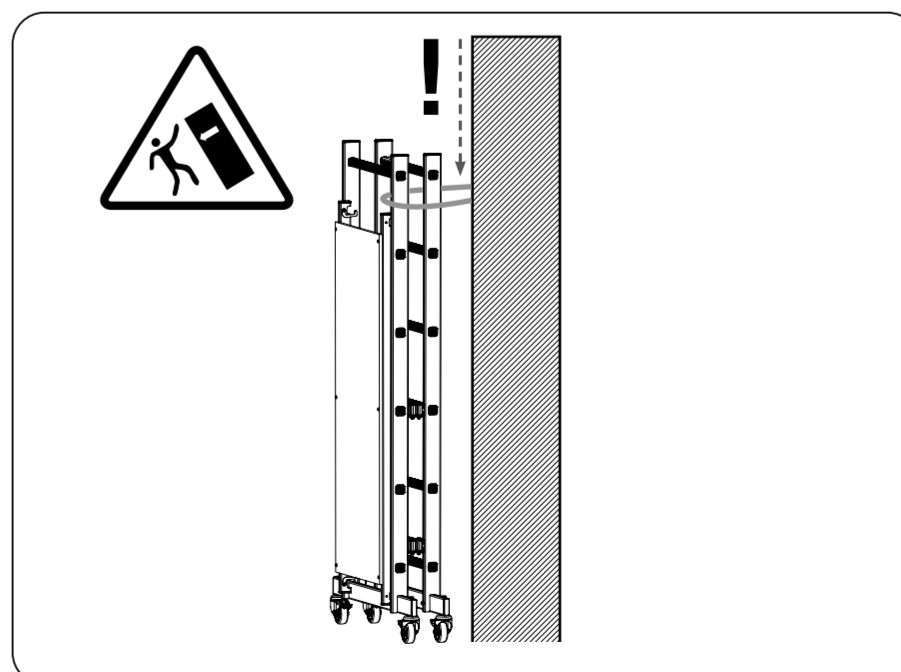
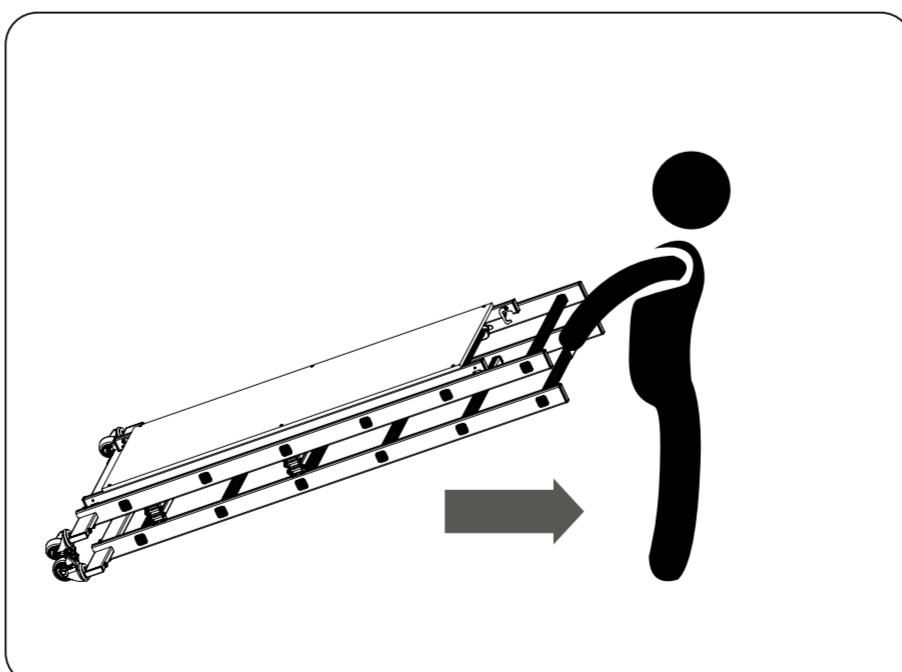
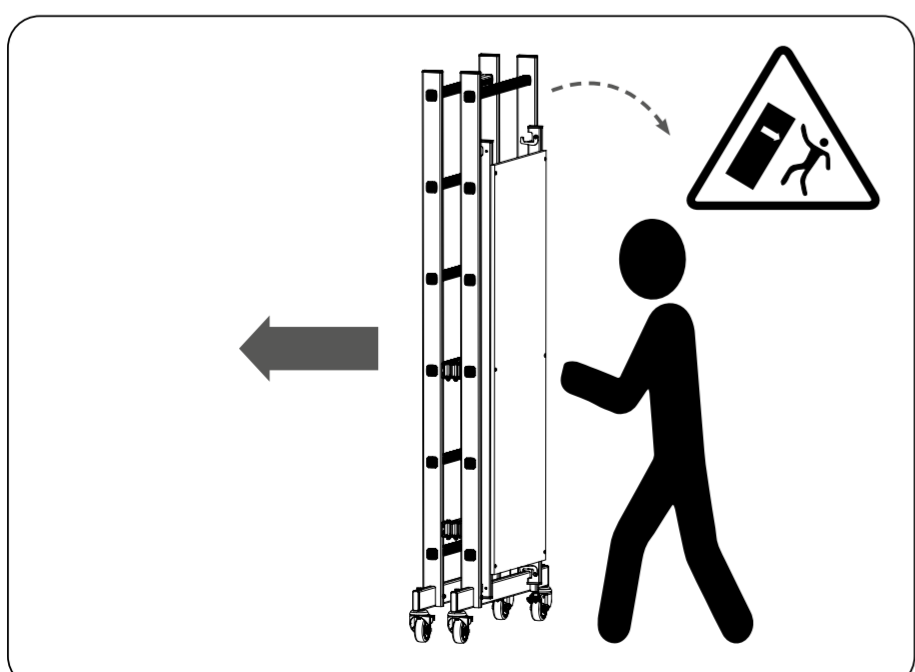
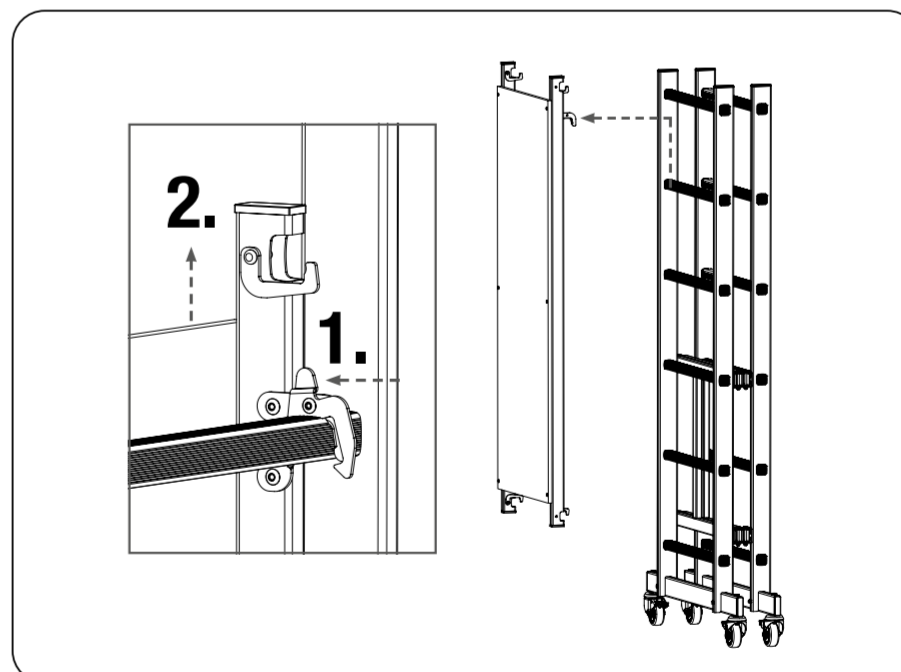
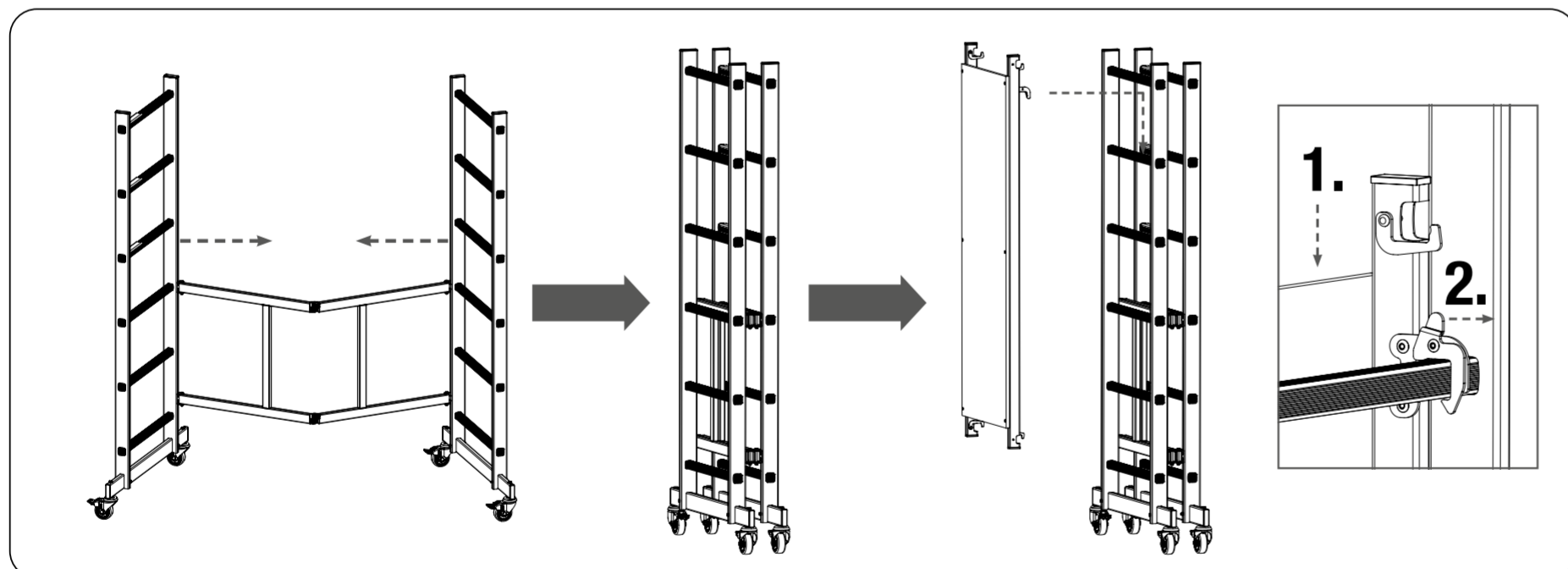
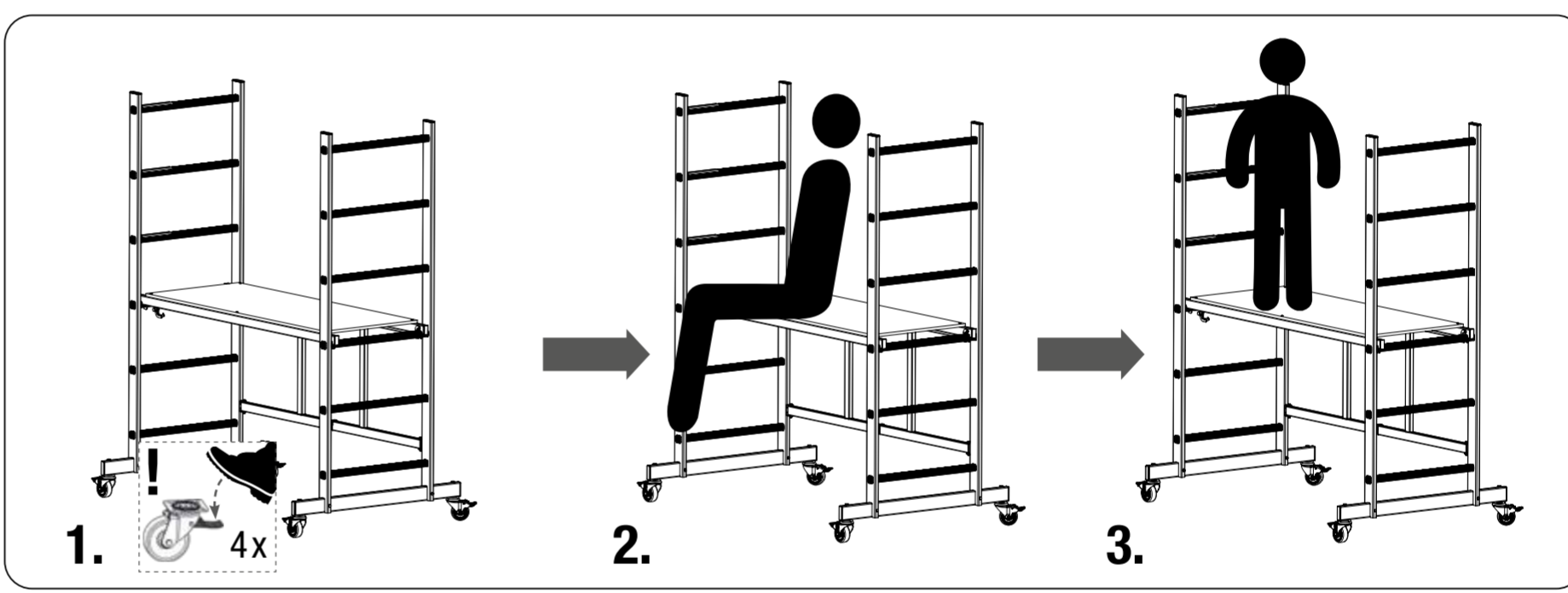
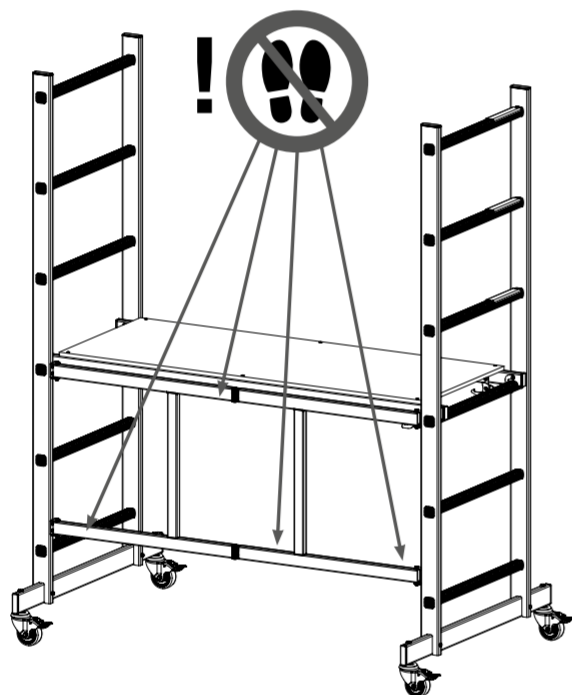
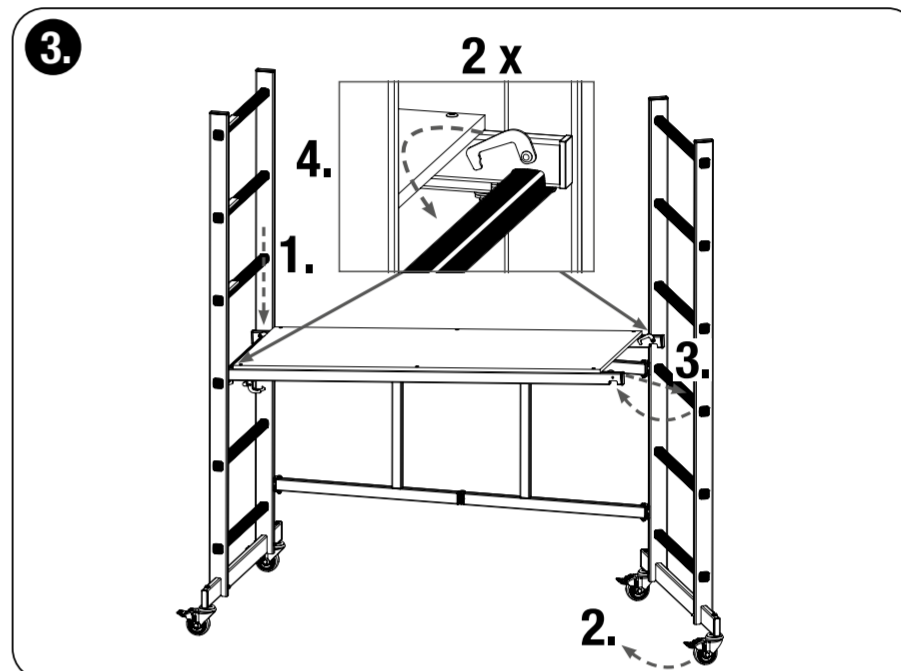
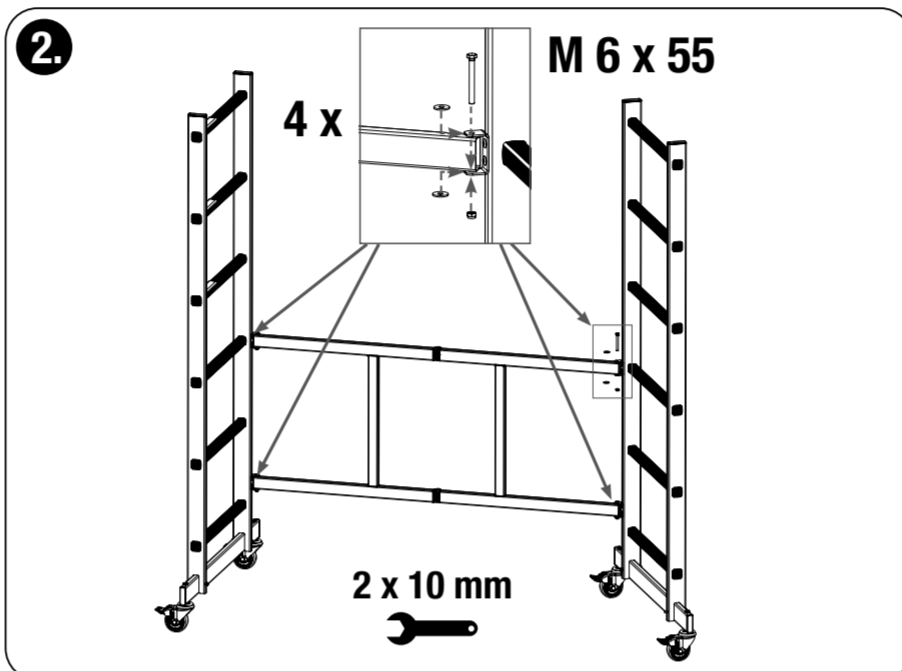
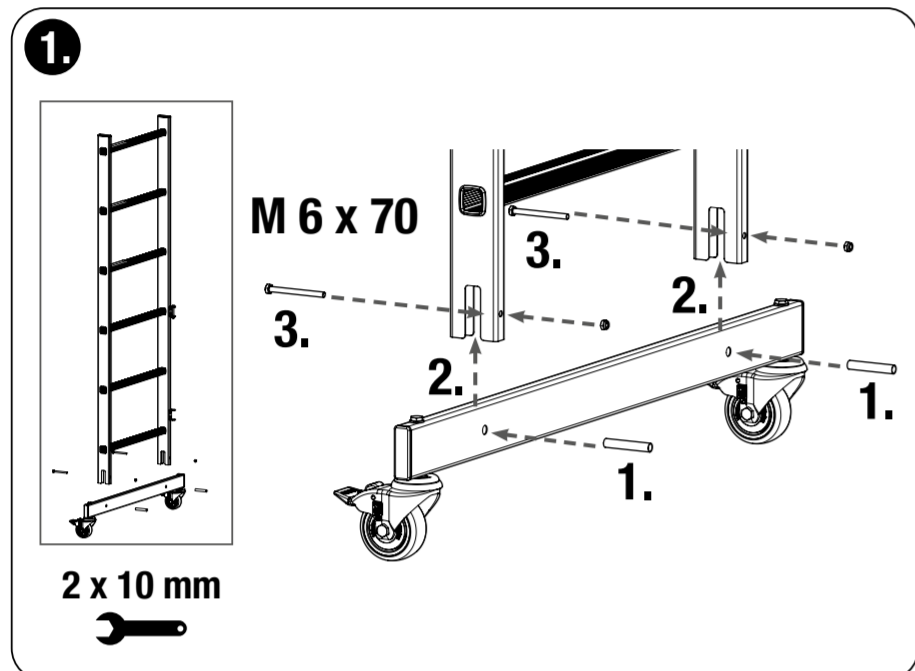
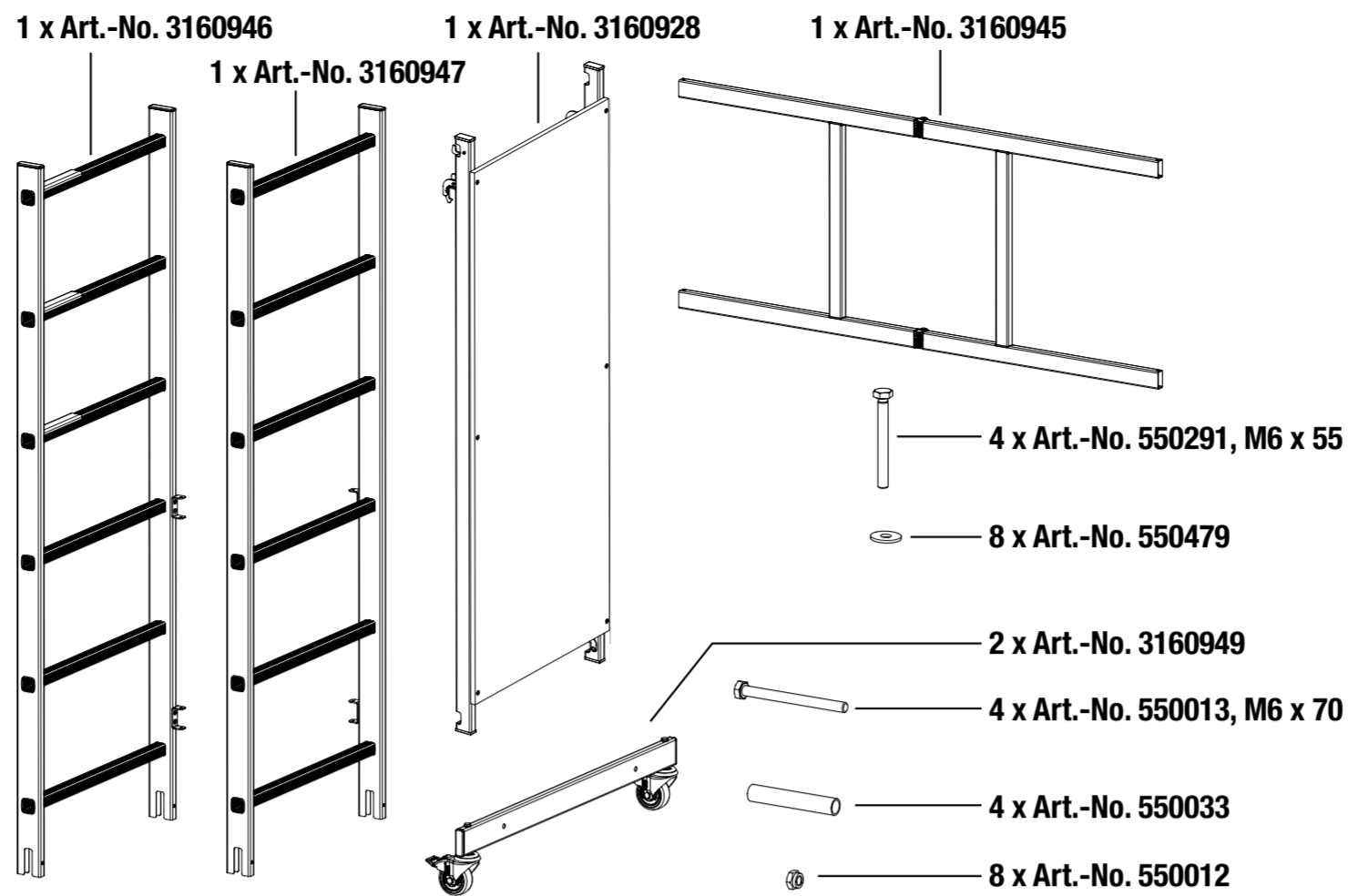

- | | | | | | | | | | |
|---|---|---|--|--|---|---|---|--|---|
| <p>DE</p> <p>1. Technische Änderungen, Druckfehler und Irrtümer vorbehalten.</p> <p>2. EXTRAS und Arbeitsmittel sind nicht im Lieferumfang enthalten!</p> <p>3. Beschädigte Gerüstteile sind unverzüglich auszutauschen.</p> <p>4. Für unsachgemäße Behandlung wird keine Haftung übernommen.</p> <p>5. Nur original KRAUSE-Ersatzteile verwenden.</p> | <p>GB</p> <p>1. We reserve the right to make technical changes and do not accept any liability for printing errors and mistakes.</p> <p>2. EXTRAS and working utensils are not included in the delivery!</p> <p>3. Damaged scaffold parts must be withdrawn from circulation immediately.</p> <p>4. No liability for improper use.</p> <p>5. Only use original KRAUSE-Accessories.</p> | <p>PL</p> <p>1. Zastrzeżeniem zmian technicznych, błędów w druku i pomylkach.</p> <p>2. Dostawa nie zawiera akcesoriów i wyposażenia dodatkowego!</p> <p>3. Uszkodzone elementy rusztowań należy natychmiast wycofać z użytku.</p> <p>4. Za użytkowanie niezgodne z przeznaczeniem nie ponosimy odpowiedzialności.</p> <p>5. Używać tylko oryginalnych części zamiennych KRAUSE.</p> | <p>HU</p> <p>1. Műszaki módosítások, nyomdai hibák és tévedések joga fenntartva.</p> <p>2. A tartozékok és szerszámok nem képezik részét a terméknek!</p> <p>3. Sérült állványelemeket azonnal ki kell cserélni.</p> <p>4. Szakszerűlen kezelésként nem vállalunk felelősséget.</p> <p>5. Csak eredeti pótalkatrészt használható fel.</p> | <p>RU</p> <p>1. Возможны технические изменения, опечатки и оmissions.</p> <p>2. Принадлежности и подручные средства не включены в объем поставки.</p> <p>3. Поврежденные элементы строительных лесов надлежит незамедлительно заменить на новые.</p> <p>4. За использование несоответственно с назначением ответственности не несем.</p> <p>5. Использовать только оригинальные запчасти.</p> | <p>CZ</p> <p>1. Technická změny, tiskové chyby a omly vyhrazeny.</p> <p>2. Dodávka neobsahuje příslušenství a další dodatečné vybavení!</p> <p>3. Defektné stĺpy a defektné diely štítorov skali udfiktés straks.</p> <p>4. Inlet erstatningsansvar ved forkert anvendelse.</p> <p>5. Kun original tilbehør må anvendes.</p> | <p>DK</p> <p>1. Der tages forbehold for tekniske ændringer, fejl og trykfejl.</p> <p>2. EKSTRAS og arbejdsredskaber er ikke inkluderet i leveringen!</p> <p>3. Defekte stiger og defekte dele til stiger skal udskiftes straks.</p> <p>4. Inlet erstatningsansvar ved forkert anvendelse.</p> <p>5. Kun original tilbehør må anvendes.</p> | <p>ES</p> <p>1. Modificaciones técnicas, errores de impresión y omisiones reservadas.</p> <p>2. EXTRAS y medios de trabajo no están contenidos en el volumen de suministro!</p> <p>3. Las piezas dañadas hay que intercambiarlas de inmediato.</p> <p>4. En caso de un tratamiento inadecuado no nos haremos cargo.</p> <p>5. Utilizar solo piezas de recambio originales.</p> | <p>IT</p> <p>1. Salvo modifiche tecniche, errori di stampa ed omissioni.</p> <p>2. Gli Accessori e gli strumenti di lavoro non sono in dotazione.</p> <p>3. Si votre article est endommagé, veuillez le remplacer immédiatement.</p> <p>4. Toute utilisation non-conforme n'est effectuée sous garantie.</p> <p>5. Seule utilisation de pièces d'origine.</p> | <p>NO</p> <p>1. Med forbehold om tekniske endringer, trykfeil og andre feil.</p> <p>2. TILBEHØR og hjelpemidler er ikke inkludert i leveringomfanget.</p> <p>3. Skadede stillasdelar må umiddelbart skiftes ut.</p> <p>4. Vi har intet ansvar for feil håndtering.</p> <p>5. Bruk kun originale reservedeler fra KRAUSE.</p> |
|---|---|---|--|--|---|---|---|--|---|